

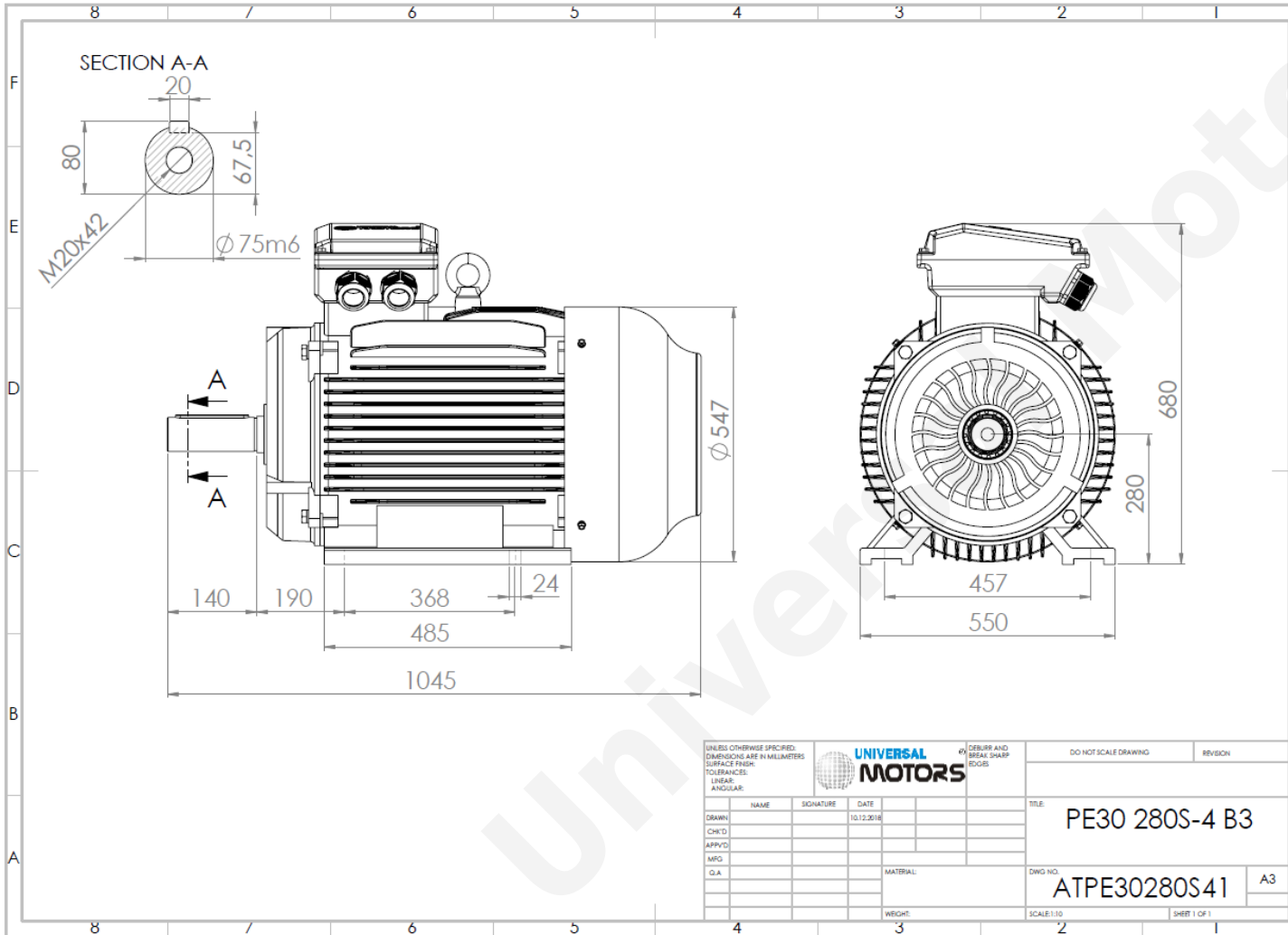

TECHNICAL DATA

Three Phase Electric Motors - Cast Iron Frame
 PE30 280S-8
 37 kW / 50 Cv
 740 RPM



Motor type:	PE30 280S-8
Output:	37 kW / 50 Cv
Speed (min ⁻¹):	740 RPM
Frequency:	50 Hz
Voltage:	400 V
Current:	73.6 A
Power factor (Cos ϕ):	0.79
Poles:	8
Insulation class:	F
Temperature rise Class:	B
Efficiency 50%:	90.9 %
Efficiency 75%:	91.9 %
Efficiency 100%:	91.8 %
Torque:	477 N.m
Tstarting/Tnominal:	1.9
Istarting/Inominal:	6.6
Tmaximum/Tnominal:	2.0
Noise:	76 Db(A)
Weight:	561 Kg
Bearing DE:	6317 C3
Bearing NDE:	6317 C3

Regime - S1

Altitude - 1000m

Environment Temperature - 40°C

CONTACTS:

UNIVERSAL MOTORS Tel: +351 252 299 080
 Rua de São Brás, 745 Fax: +351 252 299 089
 4480-782 VILA DO CONDE Mail: geral@universalmotors.pt

* References applied only in the UK